



**Gianni
Ferrari**

PROFESSIONAL MOWERS



CATALOGO PARTI DI RICAMBIO
CATALOGUE PIECES DATA CHEES
ERSATZTEILKATALOG
PARTS MANUAL

01.10.2009

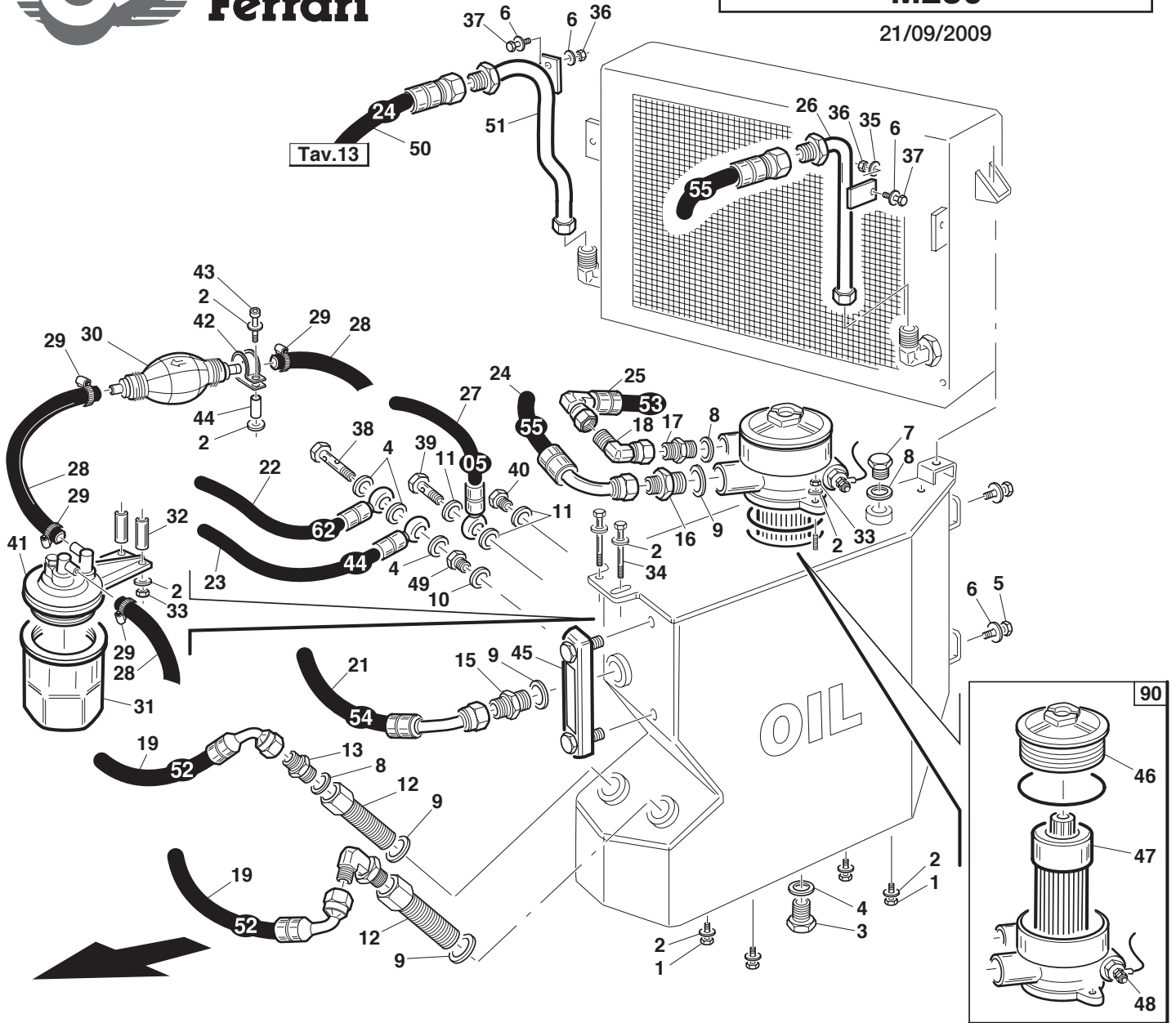

Ref.	Leg.	Code	Q.ty	Ref.	Leg.	Code	Q.ty	Ref.	Leg.	Code	Q.ty
1		00.92.05.1070	4	19		00.41.20.0061	2	35		00.68.02.0030	2
2		00.68.01.0030	12	20		00.41.20.0073	1	36		00.26.04.0040	2
3		00.85.02.0003	1	21		00.41.20.0063	1	37		00.92.03.1070	2
4		00.41.00.0070	4	22		00.41.20.0078	1	38		00.41.00.0253	1
5		00.92.03.1040	2	23		00.41.20.0053	1	39		00.41.00.0120	1
6		00.68.01.0020	4	24		00.41.20.0064	1	40		00.85.02.0002	1
7		00.85.02.0005	1	25		00.41.20.0062	1	41		00.55.01.0390	1
8		00.41.00.0073	3	26		00.41.20.0084	1	42		00.29.01.0075	1
9		00.41.00.0074	4	27		00.41.20.0014	1	43		00.90.06.0060	1
10		00.41.00.0071	1	28		00.89.02.0000	mm800	44		00.40.00.0500	1
11		00.41.00.0060	3	28		00.89.02.0000	mm470	45		00.75.00.0140	1
12		00.32.03.0070	2	28		00.89.02.0000	mm320	46		00.32.20.0011	1
13		00.41.00.0115	1	29		00.29.02.0016	4	47		00.32.20.0012	1
14		00.41.00.0878	1	30		00.99.00.0320	1	48		00.32.20.0013	1
15		00.41.00.0826	1	31		00.32.03.0040	1	49		00.41.00.0914	1
16		00.41.00.0116	1	32		01.40.00.2790	2	50		00.41.20.0082	1
17		00.41.00.0794	1	33		00.26.05.0060	3	51		00.41.20.0083	1
18		00.41.00.0868	1	34		00.92.05.1170	2	90		00.32.20.0010	1

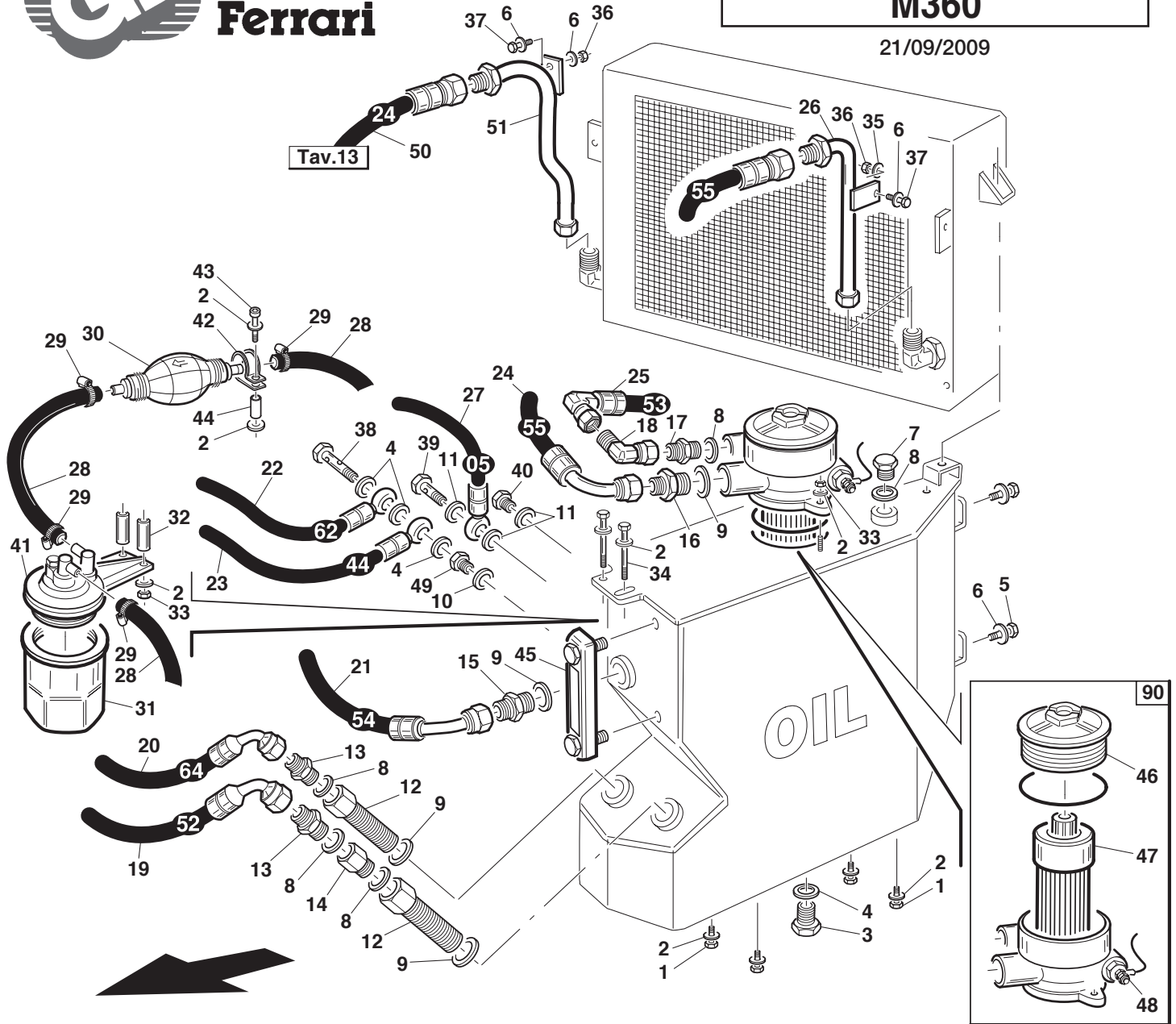

Ref.	Leg.	Code	Q.ty	Ref.	Leg.	Code	Q.ty	Ref.	Leg.	Code	Q.ty
1		00.92.05.1070	4	19		00.41.20.0061	1	35		00.68.02.0030	2
2		00.68.01.0030	12	20		00.41.20.0073	1	36		00.26.04.0040	2
3		00.85.02.0003	1	21		00.41.20.0063	1	37		00.92.03.1070	2
4		00.41.00.0070	4	22		00.41.20.0078	1	38		00.41.00.0253	1
5		00.92.03.1040	2	23		00.41.20.0053	1	39		00.41.00.0120	1
6		00.68.01.0020	4	24		00.41.20.0064	1	40		00.85.02.0002	1
7		00.85.02.0005	1	25		00.41.20.0062	1	41		00.55.01.0390	1
8		00.41.00.0073	5	26		00.41.20.0084	1	42		00.29.01.0075	1
9		00.41.00.0074	4	27		00.41.20.0014	1	43		00.90.06.0060	1
10		00.41.00.0071	1	28		00.89.02.0000	mm800	44		00.40.00.0500	1
11		00.41.00.0060	3	28		00.89.02.0000	mm470	45		00.75.00.0140	1
12		00.32.03.0070	2	28		00.89.02.0000	mm320	46		00.32.20.0011	1
13		00.41.00.0115	2	29		00.29.02.0016	4	47		00.32.20.0012	1
14		00.41.00.0934	1	30		00.99.00.0320	1	48		00.32.20.0013	1
15		00.41.00.0826	1	31		00.32.03.0040	1	49		00.41.00.0914	1
16		00.41.00.0116	1	32		01.40.00.2790	2	50		00.41.20.0082	1
17		00.41.00.0794	1	33		00.26.05.0060	3	51		00.41.20.0083	1
18		00.41.00.0868	1	34		00.92.05.1170	2	90		00.32.20.0010	1

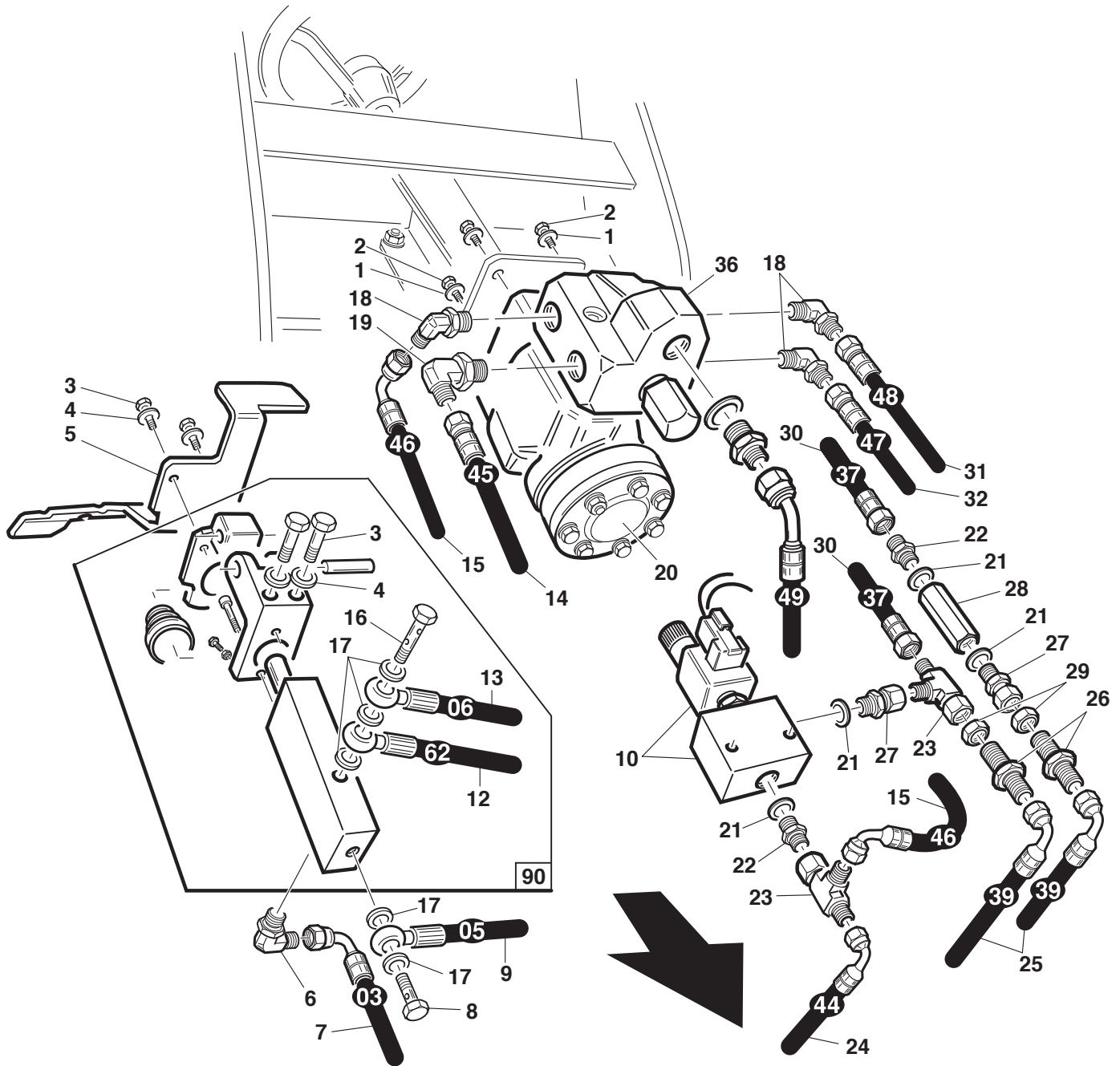

Ref.	Leg.	Code	Q.ty	Ref.	Leg.	Code	Q.ty	Ref.	Leg.	Code	Q.ty
1		00.68.12.0010	4	14		00.41.20.0054	1	26		00.41.00.0361	2
2		00.92.06.1060	4	15		00.41.20.0055	1	27		00.41.00.2822	2
3		00.92.03.1070	4	16		00.41.00.0124	1	28		00.41.00.0296	1
4		00.68.01.0020	4	17		00.41.00.0060	5	29		00.41.00.0371	2
5		01.60.20.0281	1	18		00.41.00.0875	3	30		00.41.20.0046	2
6		00.41.00.0874	1	19		00.41.00.0876	1	31		00.41.20.0057	1
7		00.41.20.0012	1	20		00.41.00.3560	1	32		00.41.20.0056	1
8		00.41.00.0120	1	21		00.41.00.0070	4	33		00.41.20.0058	1
9		00.41.20.0014	1	22		00.41.00.0110	2	34		00.41.00.0113	1
10		00.41.00.3580	1	23		00.41.00.0881	2	35		00.41.00.0071	1
12		00.41.20.0078	1	24		00.41.20.0053	1	36		00.41.00.3570	1
13		00.41.20.0015	1	25		00.41.20.0048	2				

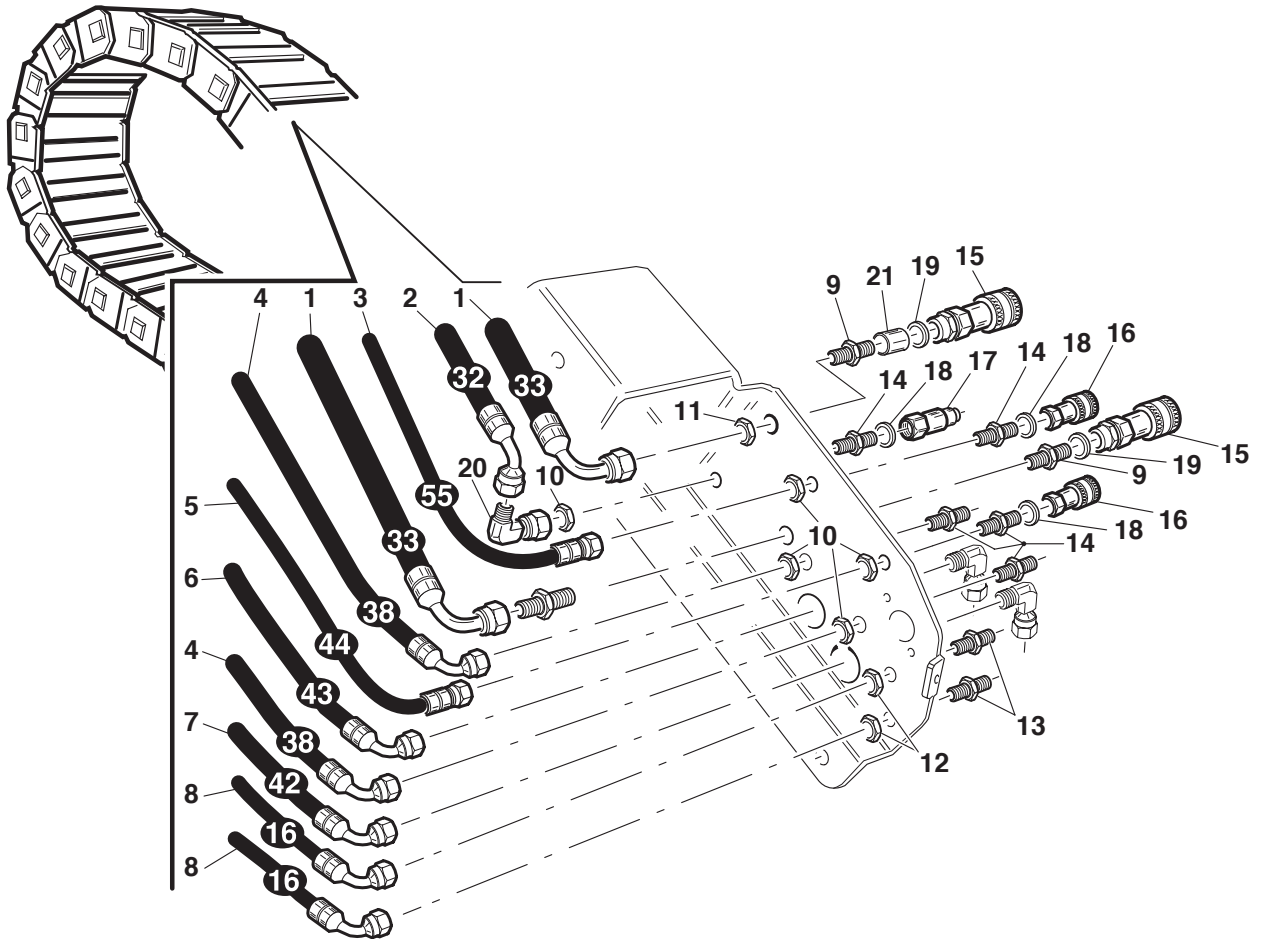

Ref.	Leg.	Code	Q.ty	Ref.	Leg.	Code	Q.ty
1		00.41.20.0042	2	12		00.41.00.0370	2
2		00.41.20.0041	1	13		00.41.00.360	2
3		00.41.20.0064	1	14		00.41.00.0361	5
4		00.41.20.0047	2	15		00.41.0.0465	2
5		00.41.20.0043	1	16		00.41.00.3762	2
6		00.41.20.0052	1	17		00.41.00.3772	1
7		00.41.20.0051	1	18		00.41.00.0070	3
8		00.41.20.0025	2	19		00.41.00.1293	2
9		00.41.00.0363	2	20		00.41.00.0871	1
10		00.41.00.0371	5	21		01.40.20.0025	1
11		00.41.00.0373	2				



Gianni Ferrari

Tav. 05 - TurboLoader

M280 - M360

21/09/2009

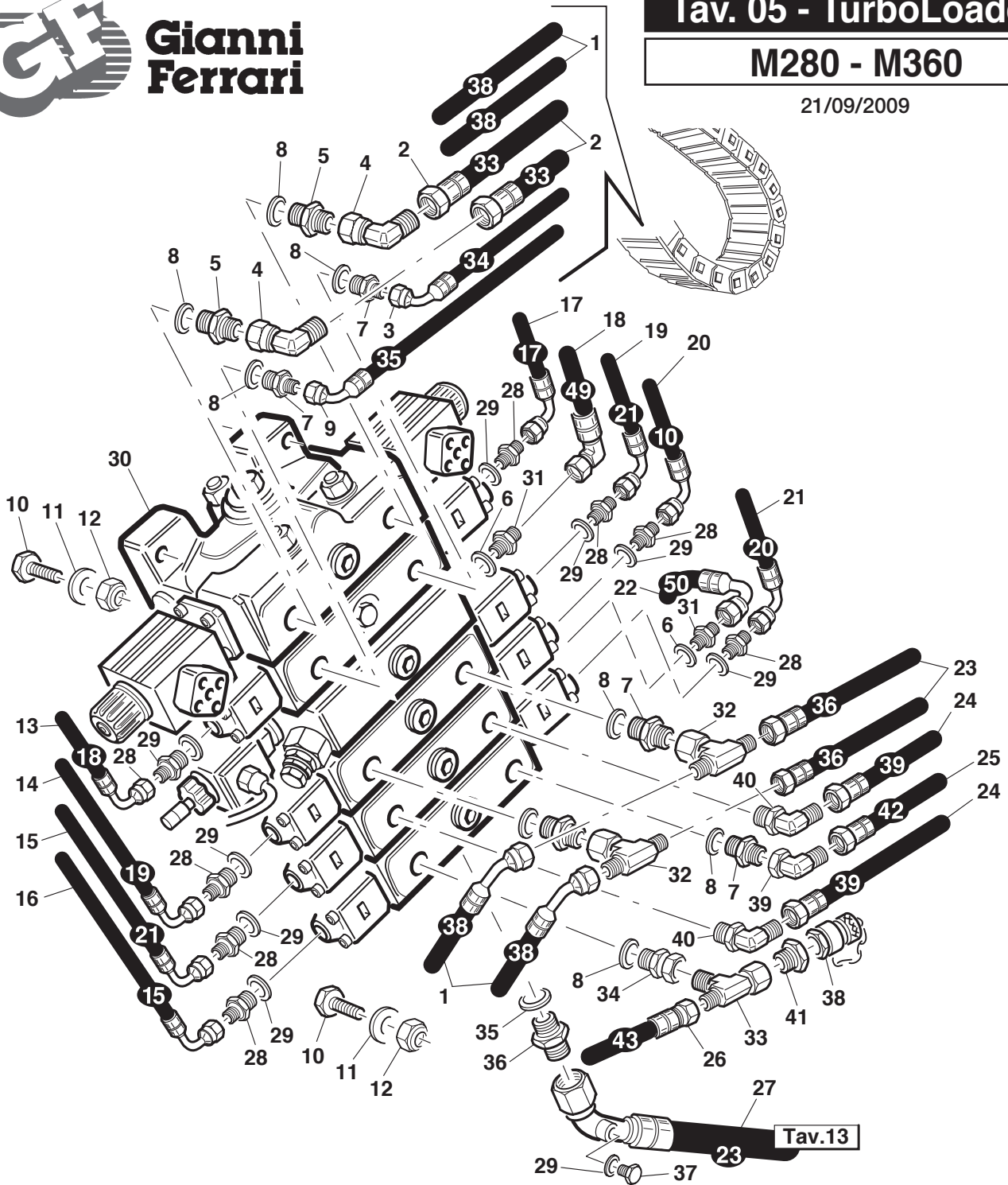

Tav.13

Ref.	Leg.	Code	Q.ty	Ref.	Leg.	Code	Q.ty	Ref.	Leg.	Code	Q.ty
1		00.41.20.0047	2	15		00.41.20.0030	1	29		00.41.00.0060	9
2		00.41.20.0042	2	16		00.41.20.0025	1	30		00.41.00.3630	1
3		00.41.20.0043	1	17		00.41.20.0026	1	31		00.41.00.0113	2
4		00.41.00.0872	2	18		00.41.20.0058	1	32		00.41.00.0731	2
5		00.41.00.0784	2	19		00.41.20.0030	1	33		00.41.00.0881	1
6		00.41.00.0071	2	20		00.41.20.0019	1	34		00.41.00.2821	1
7		00.41.00.0110	5	21		00.41.20.0029	1	35		00.41.00.0073	1
8		00.41.00.0070	8	22		00.41.20.0059	1	36		00.41.00.0794	1
9		00.41.20.0044	1	23		00.41.20.0045	2	37		00.85.02.0002	1
10		00.90.06.3130	4	24		00.41.20.0048	2	38		00.41.00.3085	1
11		00.68.01.0030	4	25		00.41.20.0051	1	39		00.41.00.0871	1
12		00.26.05.0060	4	26		00.41.20.0052	1	40		00.41.00.0875	2
13		00.41.20.0027	1	27		00.41.20.0081	1				
14		00.41.20.0028	1	28		00.41.00.0780	8				

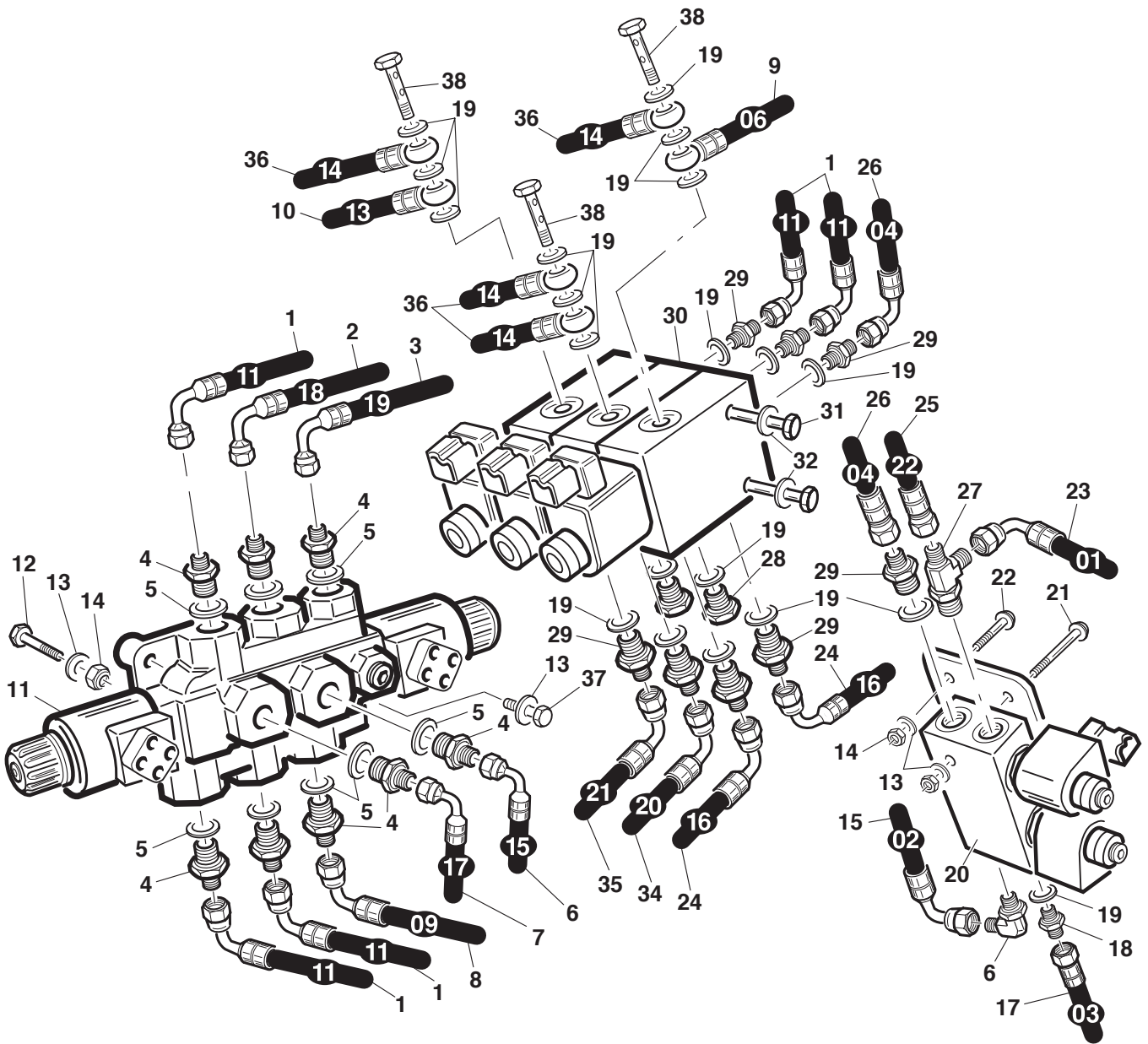

Ref.	Leg.	Code	Q.ty	Ref.	Leg.	Code	Q.ty	Ref.	Leg.	Code	Q.ty
1		00.41.20.0020	3	14		00.26.05.0060	3	27		00.41.00.2101	1
2		00.41.20.0027	1	15		00.41.20.0011	1	28		00.85.02.0002	2
3		00.41.20.0028	1	16		00.41.00.0874	1	29		00.41.00.0780	8
4		00.41.00.0781	8	17		00.41.20.0012	1	30		00.41.00.3420	3
5		00.41.00.0070	8	18		00.41.00.0450	1	31		00.92.03.0270	2
6		00.41.20.0024	1	19		00.41.00.0060	20	32		00.68.01.0020	2
7		00.41.20.0026	1	20		00.41.00.3660	1	34		00.41.20.0029	1
8		00.41.20.0018	1	21		00.90.06.3150	2	35		00.41.20.0030	1
9		00.41.20.0015	1	22		00.90.06.3100	2	36		00.41.20.0023	2
10		00.41.20.0022	1	23		00.41.20.0010	1	37		00.92.05.1120	1
11		00.41.00.3640	1	24		00.41.20.0025	2	38		00.41.00.0124	3
12		00.90.06.3130	1	25		00.41.20.0032	1	39		00.90.06.3100	2
13		00.68.01.0030	4	26		00.41.20.0013	1				

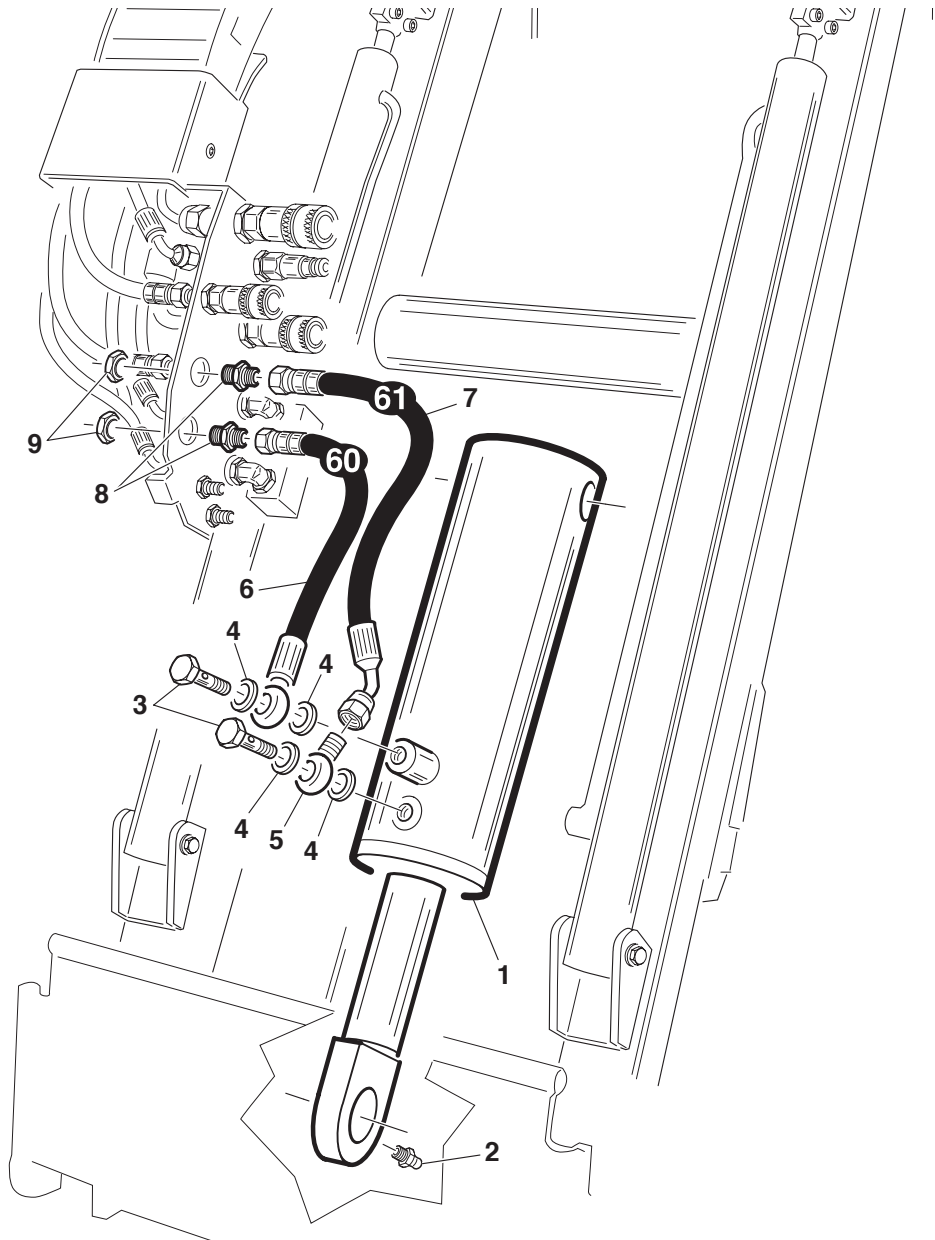

Ref.	Leg.	Code	Q.ty
1		00.58.20.0012	1
2		00.42.00.0010	1
3		00.41.00.0250	2
4		00.41.00.0070	4
5		00.41.00.0242	1
6		00.41.20.0069	1
7		00.41.20.0070	1
8		00.41.00.0361	2
9		00.41.00.0371	2

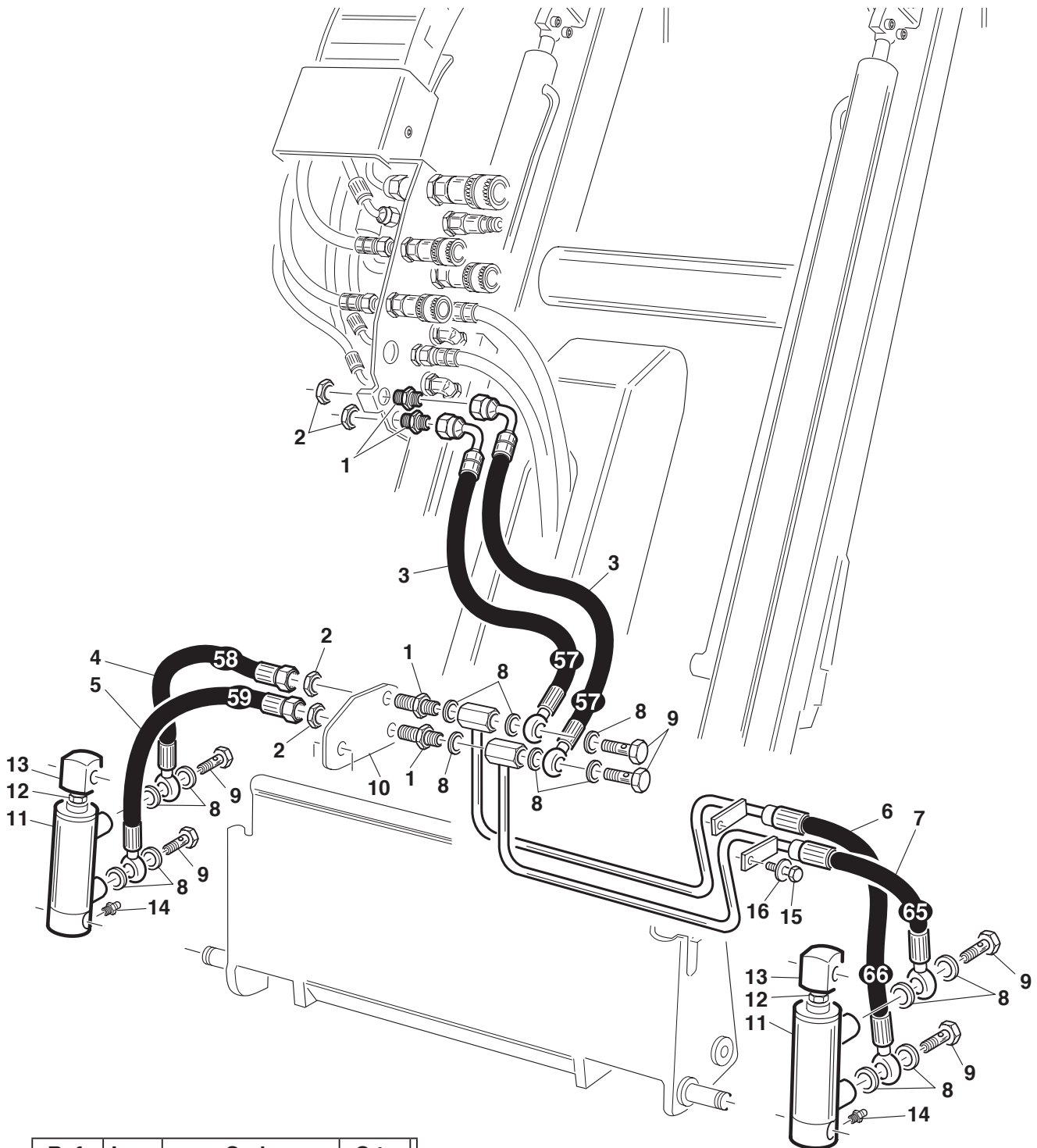

Ref.	Leg.	Code	Q.ty	Ref.	Leg.	Code	Q.ty
1		00.41.00.0360	4				
2		00.41.00.0370	4				
3		00.41.20.0066	2				
4		00.41.20.0067	1	11		00.58.20.0015	2
5		00.41.20.0068	1	12		00.26.03.0090	2
6		00.41.20.0075	1	13		00.40.20.0075	2
7		00.41.20.0074	1	14		00.42.00.0010	2
8		00.41.00.0060	14	15		00.92.05.1080	2
9		00.41.00.0120	6	16		00.68.02.0050	2
10		01.60.20.0026	1				



**Gianni
Ferrari**

Tav. 10 - TurboLoader

M220 - M280 - M360

21/09/2009

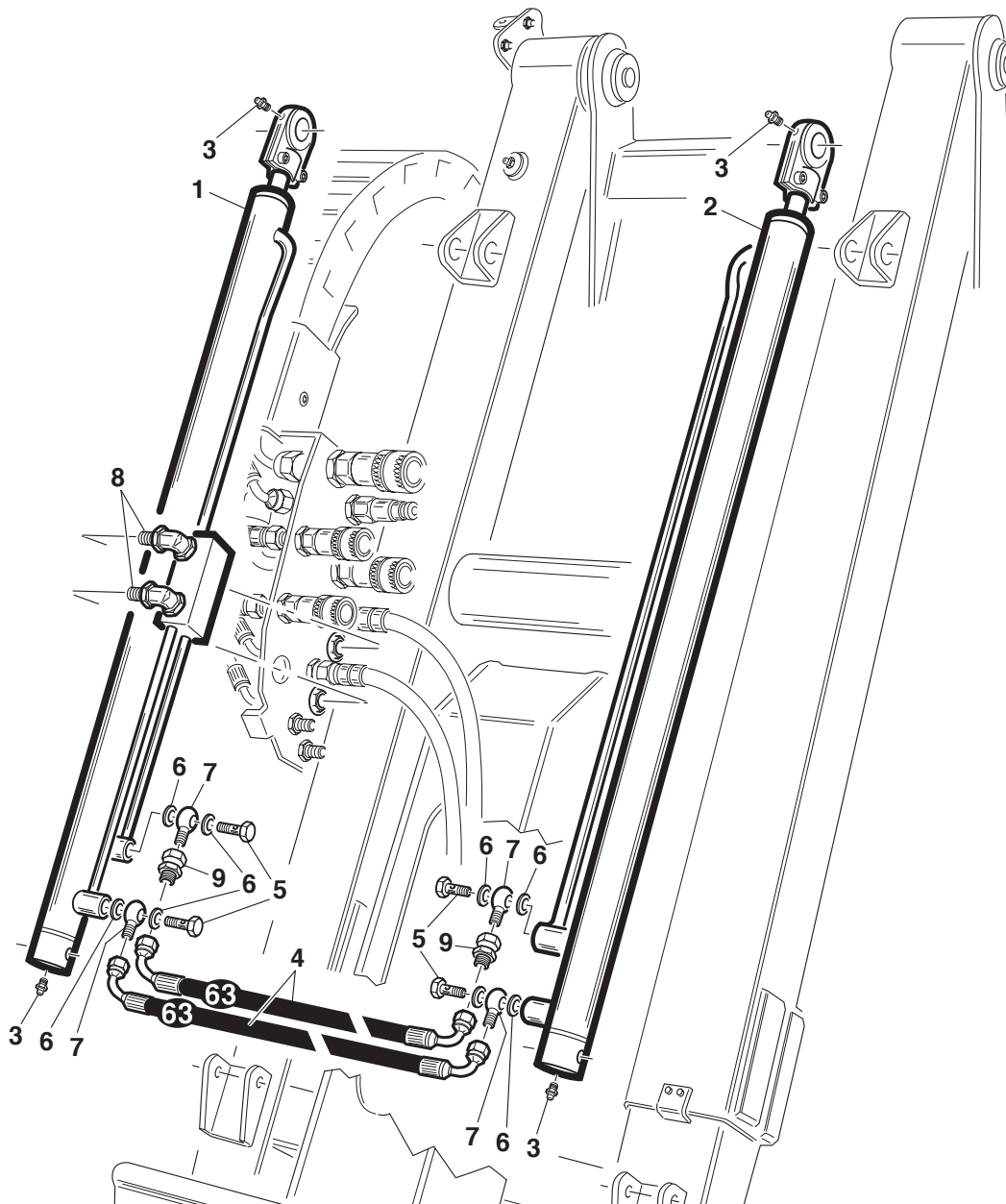

Ref.	Leg.	Code	Q.ty
1	DX	00.58.20.0016	1
2	SX	00.58.20.0010	1
3		00.42.00.0010	4
4		00.41.20.0072	2
5		00.41.20.0120	4
6		00.41.00.0060	8
7		00.41.00.0240	4
8		00.41.00.0875	2
9		00.41.00.2821	2

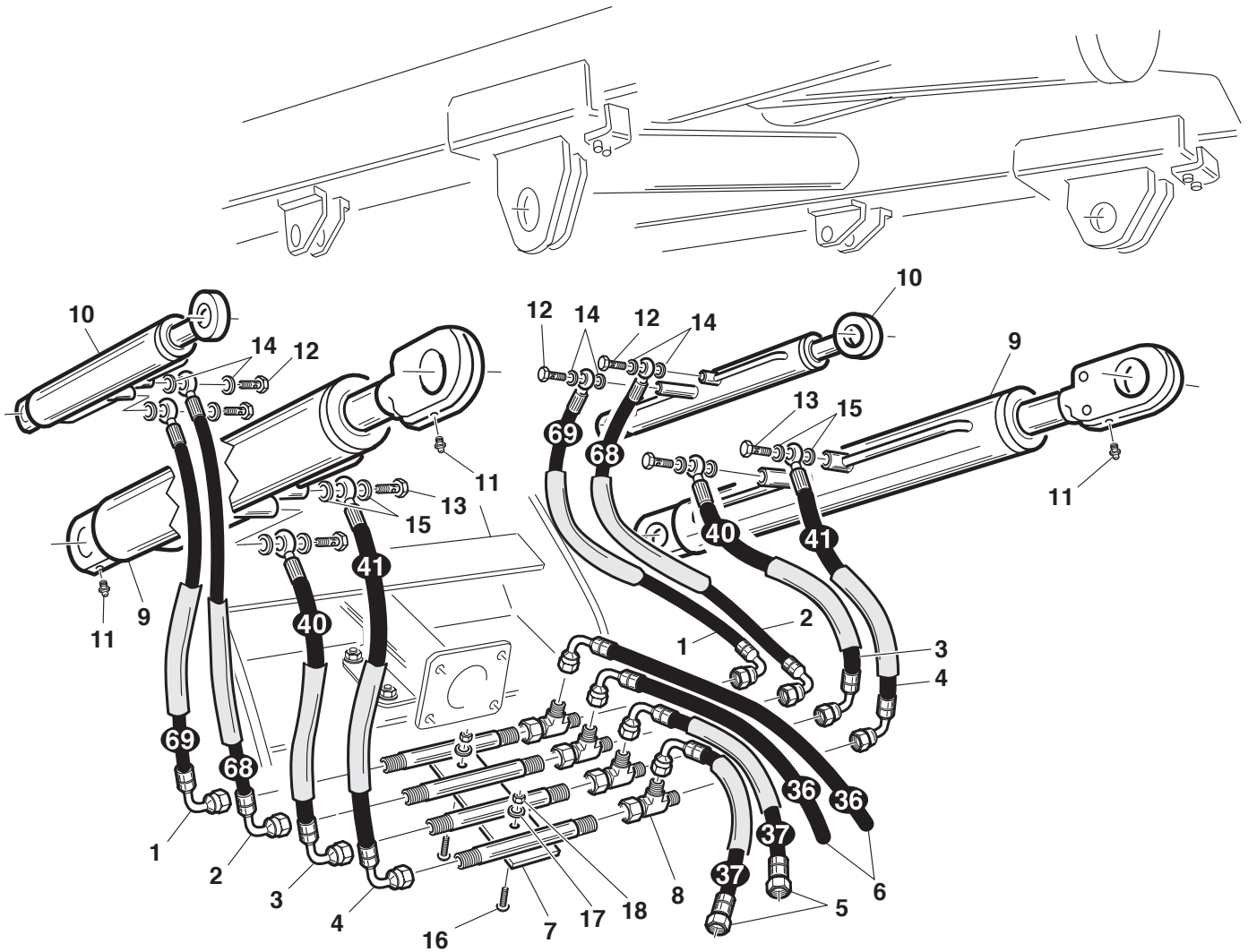

Ref.	Leg.	Code	Q.ty	Ref.	Leg.	Code	Q.ty
1		00.41.20.0080	2	10		00.58.20.0017	2
2		00.41.20.0079	2	11		00.42.00.0010	4
3		00.41.20.0049	2	12		00.41.00.0120	4
4		00.41.20.0050	2	13		00.41.00.0250	4
5		00.41.20.0046	2	14		00.41.00.0060	8
6		00.41.20.0045	2	15		00.41.00.0070	8
7		01.50.20.0102	1	16		00.90.06.3100	2
8		00.41.00.0881	4	17		00.68.01.0030	2
9		00.58.20.0011	2	18		00.26.05.0060	2

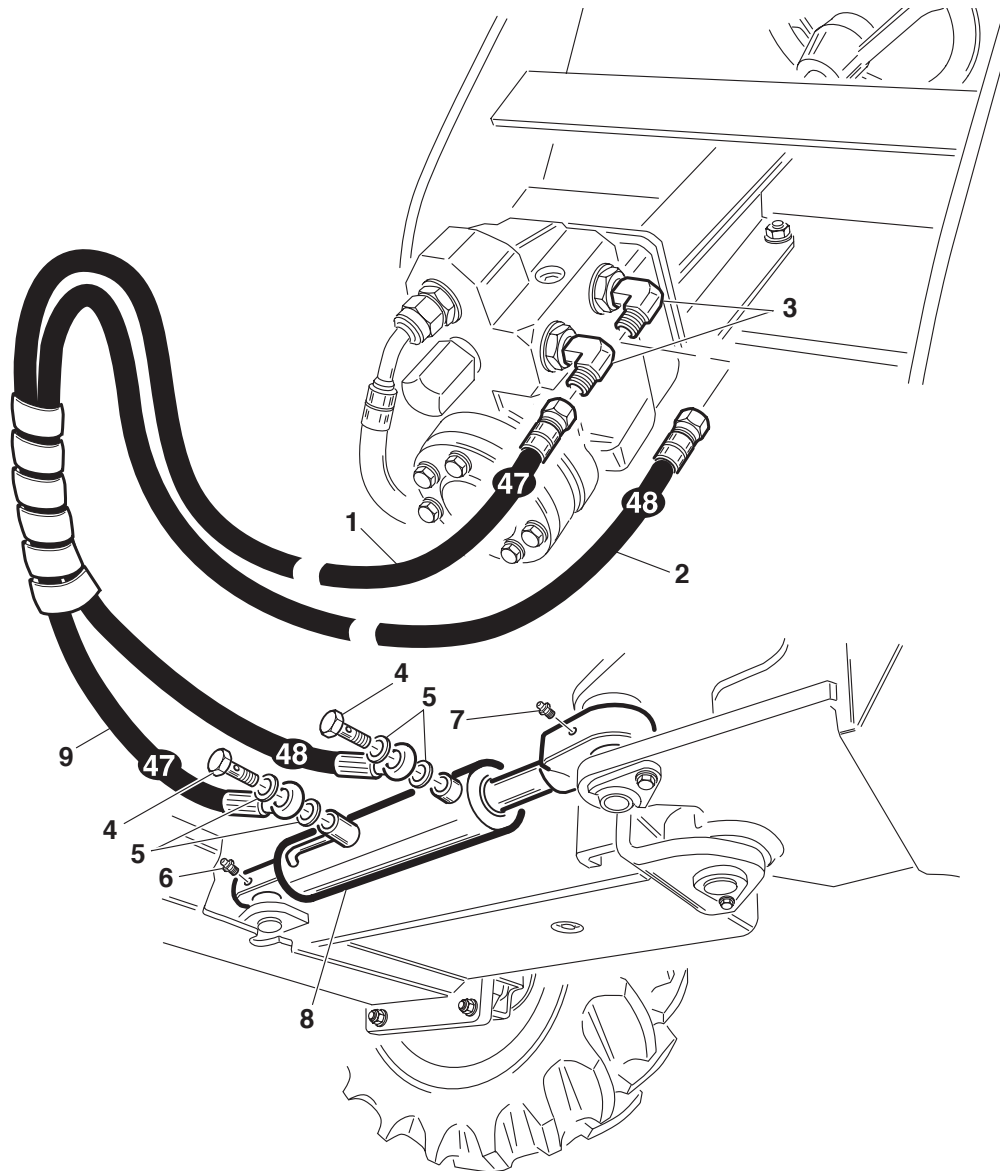

Ref.	Leg.	Code	Q.ty
1		00.41.20.0056	1
2		00.41.20.0057	1
3		00.41.00.0875	2
4		00.41.00.0280	2
5		00.41.00.0070	4
6		00.42.00.0010	1
7		00.42.00.0030	1
8		00.58.20.0013	1
9		00.07.01.0184	0,15m

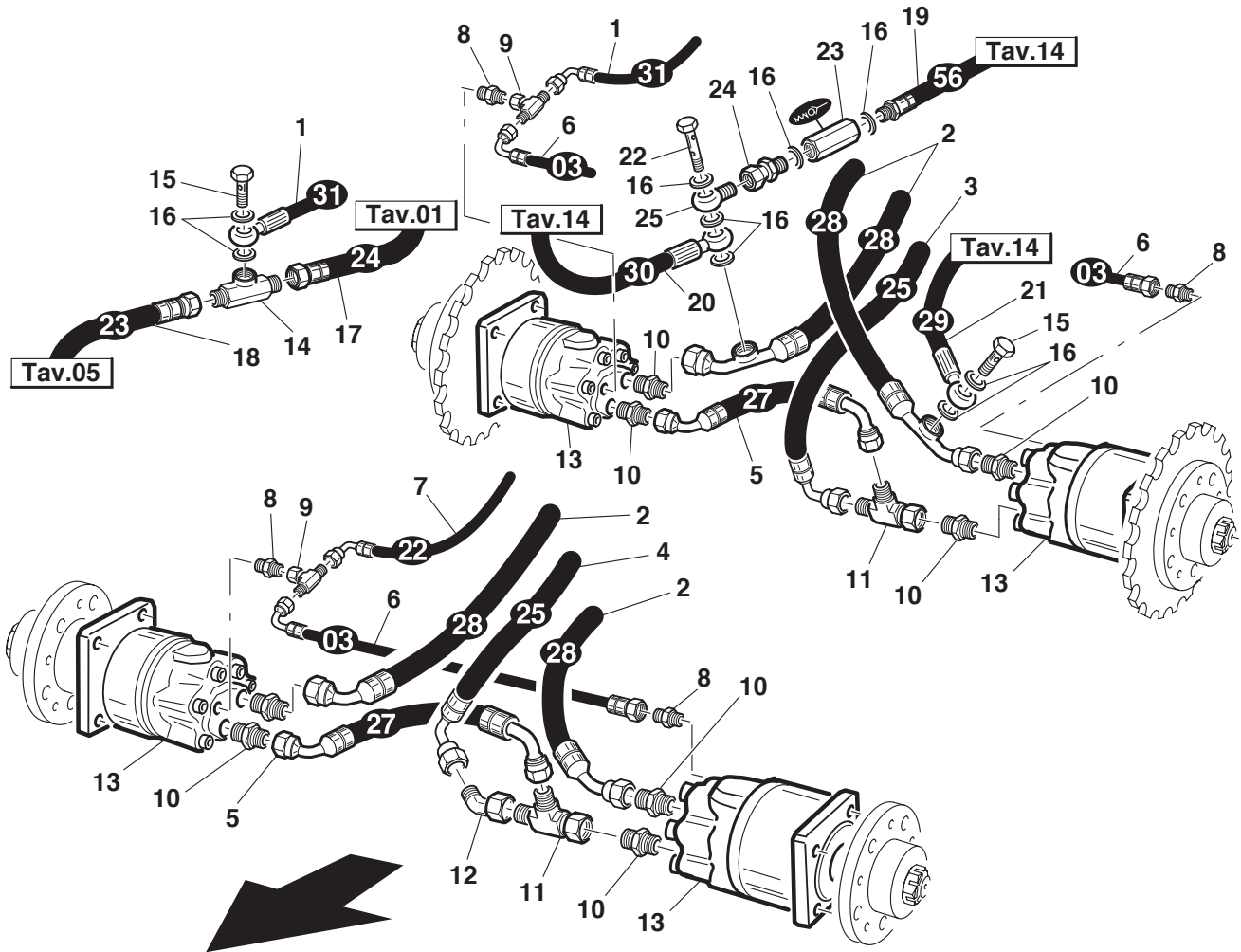

Ref.	Leg.	Code	Q.ty	Ref.	Leg.	Code	Q.ty
1		00.41.20.0040	1	13		00.54.00.1170	4
2		00.41.20.0037	4	14		00.41.00.0096	1
3		00.41.20.0035	1	15		00.41.00.0120	1
4	M360	00.41.20.0076	1	16		00.41.00.0060	9
4	M280	00.41.20.0034	1	17		00.41.20.0082	1
5		00.41.20.0036	2	18		00.41.20.0081	1
6		00.41.20.0012	2	19		00.41.20.0065	1
7		00.41.20.0032	1	20		00.41.20.0039	1
8		00.41.00.0810	4	21		00.41.20.0038	1
9		00.41.00.0730	2	22		00.41.00.0124	1
10		00.41.00.1275	8	23		00.41.00.0292	1
11		00.41.00.1265	2	24		00.41.00.2821	1
12		00.41.00.0965	1	25		00.41.00.0240	1



**Gianni
Ferrari**

Tav. 14 - TurboLoader

M280 - M360

21/09/2009

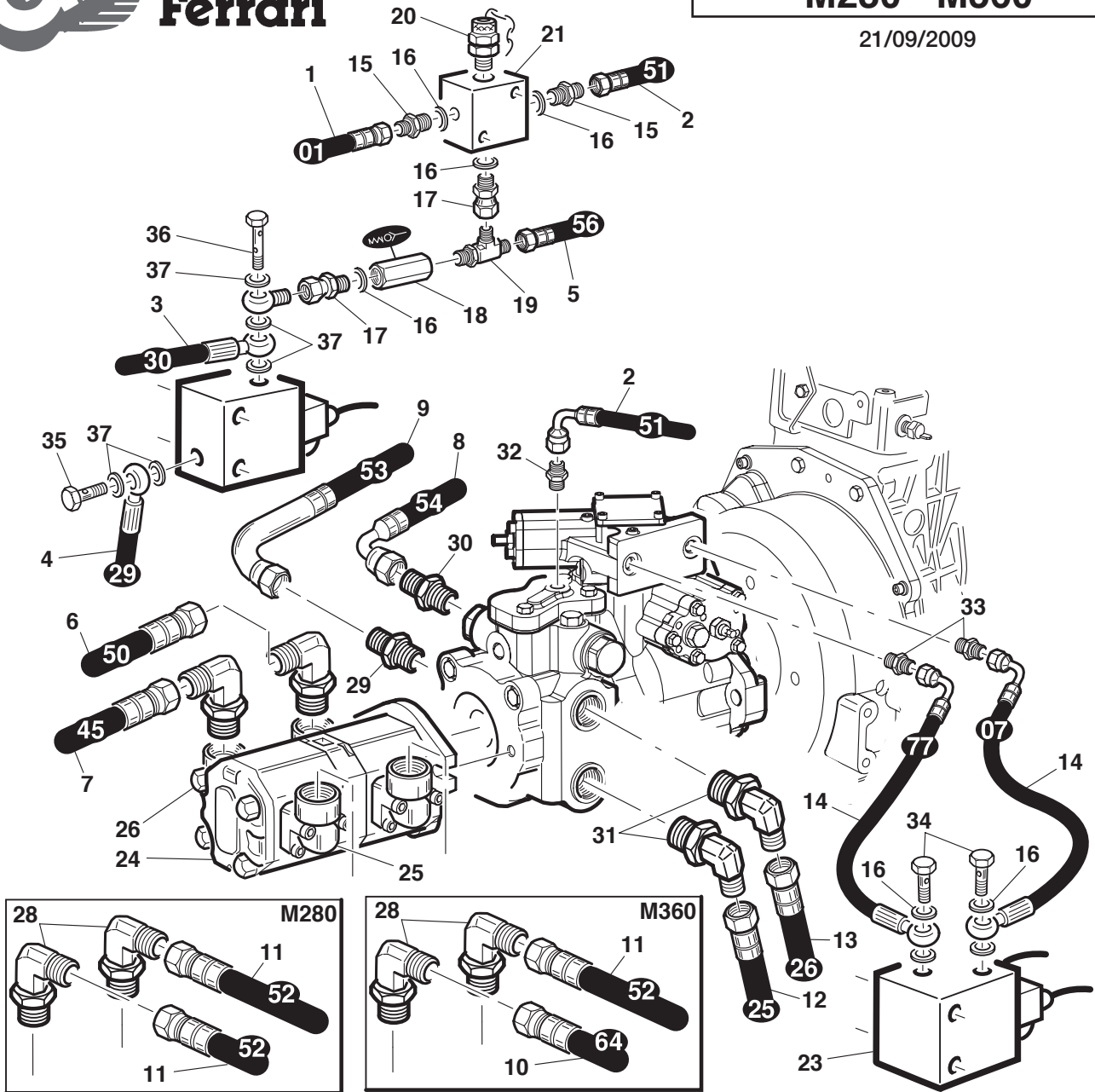

Ref.	Leg.	Code	Q.ty	Ref.	Leg.	Code	Q.ty	Ref.	Leg.	Code	Q.ty
1		00.41.20.0010	1	12	M280	00.41.20.0034	1	27		00.41.00.0876	2
2		00.41.20.0060	2	13		00.41.20.0035	1	28		00.41.00.0878	2
3		00.41.20.0039	1	14		00.41.20.0016	2	29		00.41.00.0828	1
4		00.41.20.0038	1	15		00.41.00.0450	2	30		00.41.00.1276	1
5		00.41.20.0065	1	16		00.41.00.0060	8	31		00.41.00.2869	2
6	M360	00.41.20.0086	1	17		00.41.00.2821	2	32		00.41.00.0812	1
6	M280	00.41.20.0059	1	18		00.41.00.0292	1	33		00.41.00.0810	2
7	M360	00.41.20.0085	1	19		00.41.00.2101	1	34		00.41.00.0120	2
7	M280	00.41.20.0054	1	20		00.41.00.3085	1	35		00.41.00.0250	1
8		00.41.20.0062	1	21		00.41.00.1920	1	36		00.41.00.0253	1
9		00.41.20.0063	1	22		00.41.00.3580	1	37		00.41.00.0070	5
10	M360	00.41.20.0073	1	23		00.41.00.3423	1	38		00.41.00.0241	1
11	M360	00.41.20.0061	1	24		00.41.00.3550	1	39		00.41.00.3540	1
11	M280	00.41.20.0061	2	25		00.41.00.0189	2				
12	M360	00.41.20.0076	1	26		00.41.00.0188	2				

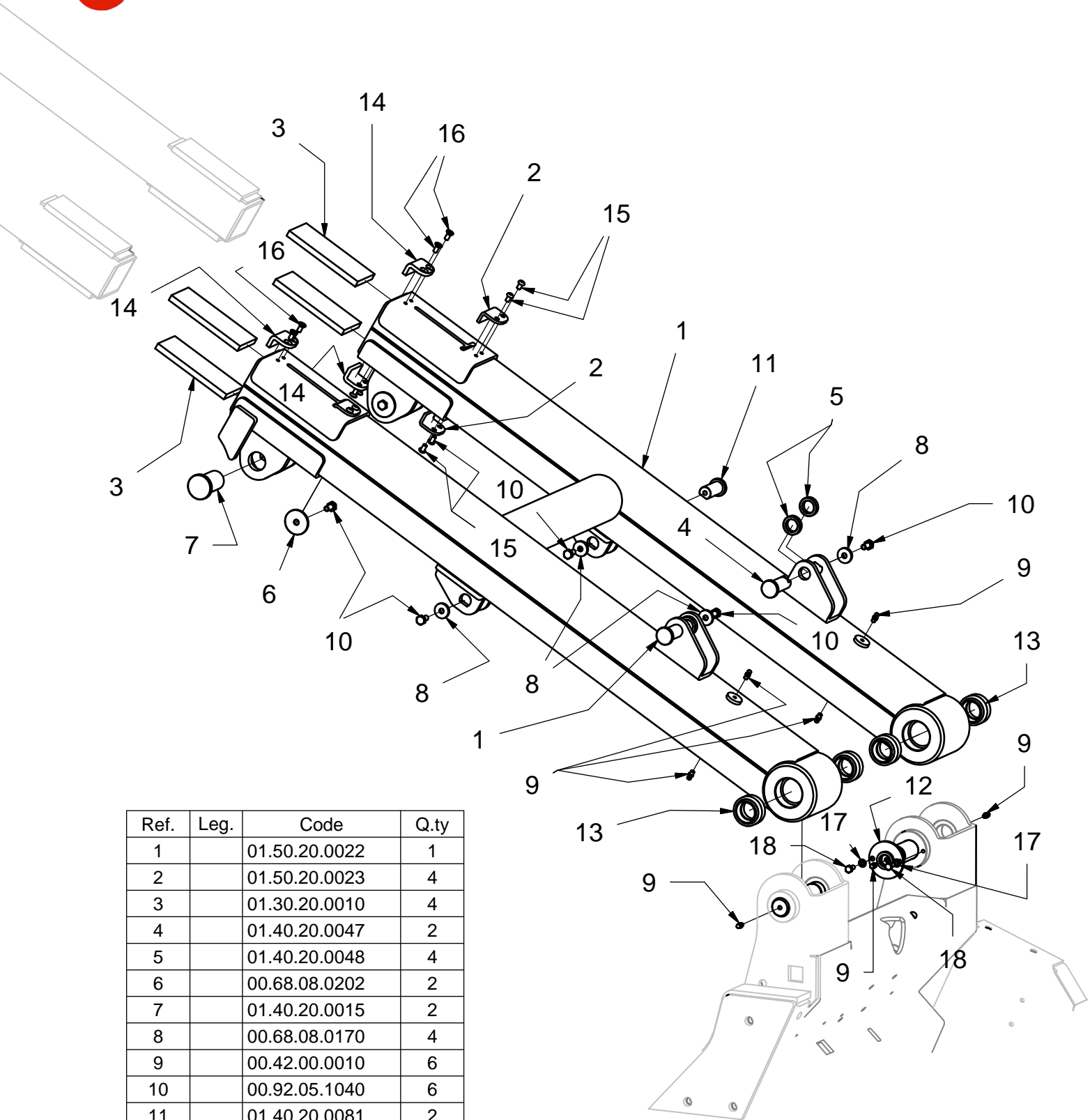

Ref.	Leg.	Code	Q.ty
1		01.50.20.0022	1
2		01.50.20.0023	4
3		01.30.20.0010	4
4		01.40.20.0047	2
5		01.40.20.0048	4
6		00.68.08.0202	2
7		01.40.20.0015	2
8		00.68.08.0170	4
9		00.42.00.0010	6
10		00.92.05.1040	6
11		01.40.20.0081	2
12		01.50.20.0096	2
13		00.78.03.2100	4
14		01.60.20.0460	4
15		00.90.04.3030	8
16		00.95.04.0030	8
17		00.68.01.0020	4
18		00.92.03.1040	4

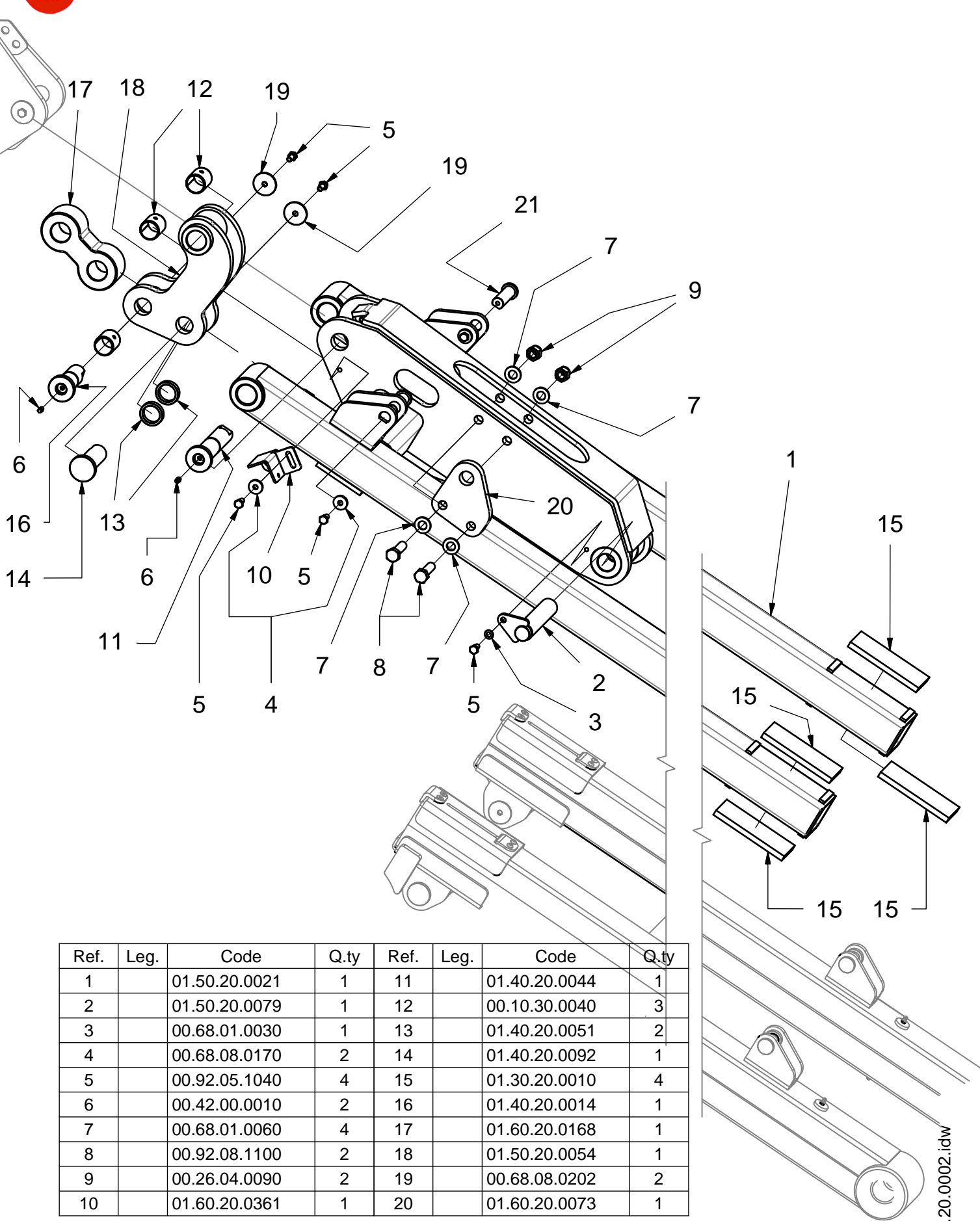

Ref.	Leg.	Code	Q.ty	Ref.	Leg.	Code	Q.ty
1		01.50.20.0021	1	11		01.40.20.0044	1
2		01.50.20.0079	1	12		00.10.30.0040	3
3		00.68.01.0030	1	13		01.40.20.0051	2
4		00.68.08.0170	2	14		01.40.20.0092	1
5		00.92.05.1040	4	15		01.30.20.0010	4
6		00.42.00.0010	2	16		01.40.20.0014	1
7		00.68.01.0060	4	17		01.60.20.0168	1
8		00.92.08.1100	2	18		01.50.20.0054	1
9		00.26.04.0090	2	19		00.68.08.0202	2
10		01.60.20.0361	1	20		01.60.20.0073	1

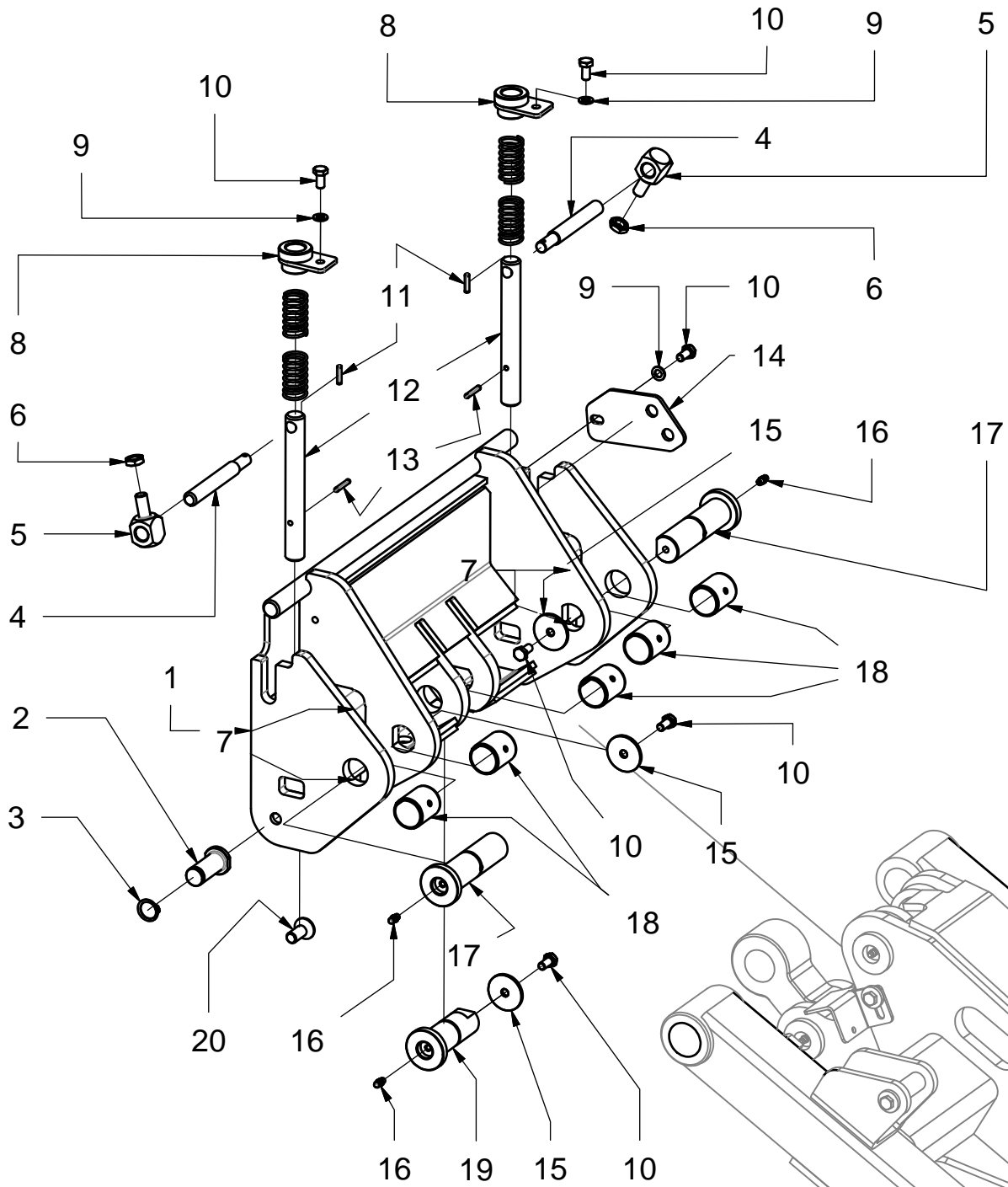

Ref.	Leg.	Code	Q.ty	Ref.	Leg.	Code	Q.ty
1		01.50.20.0030	1	11		00.83.11.1020	2
2		01.40.20.0076	2	12		01.40.20.0039	2
3		00.03.00.0160	2	13		00.83.11.1026	2
4		01.40.20.0040	2	14		01.60.20.0026	1
5		01.40.20.0075	2	15		00.68.08.0202	3
6		00.26.03.0090	2	16		00.42.00.0010	3
7		00.47.00.0230	4	17		01.40.20.0072	2
8		01.50.20.0055	2	18		00.10.30.0040	5
9		00.68.01.0030	3	19		01.40.20.0014	1
10		00.92.05.1040	5	20		00.95.07.0040	2

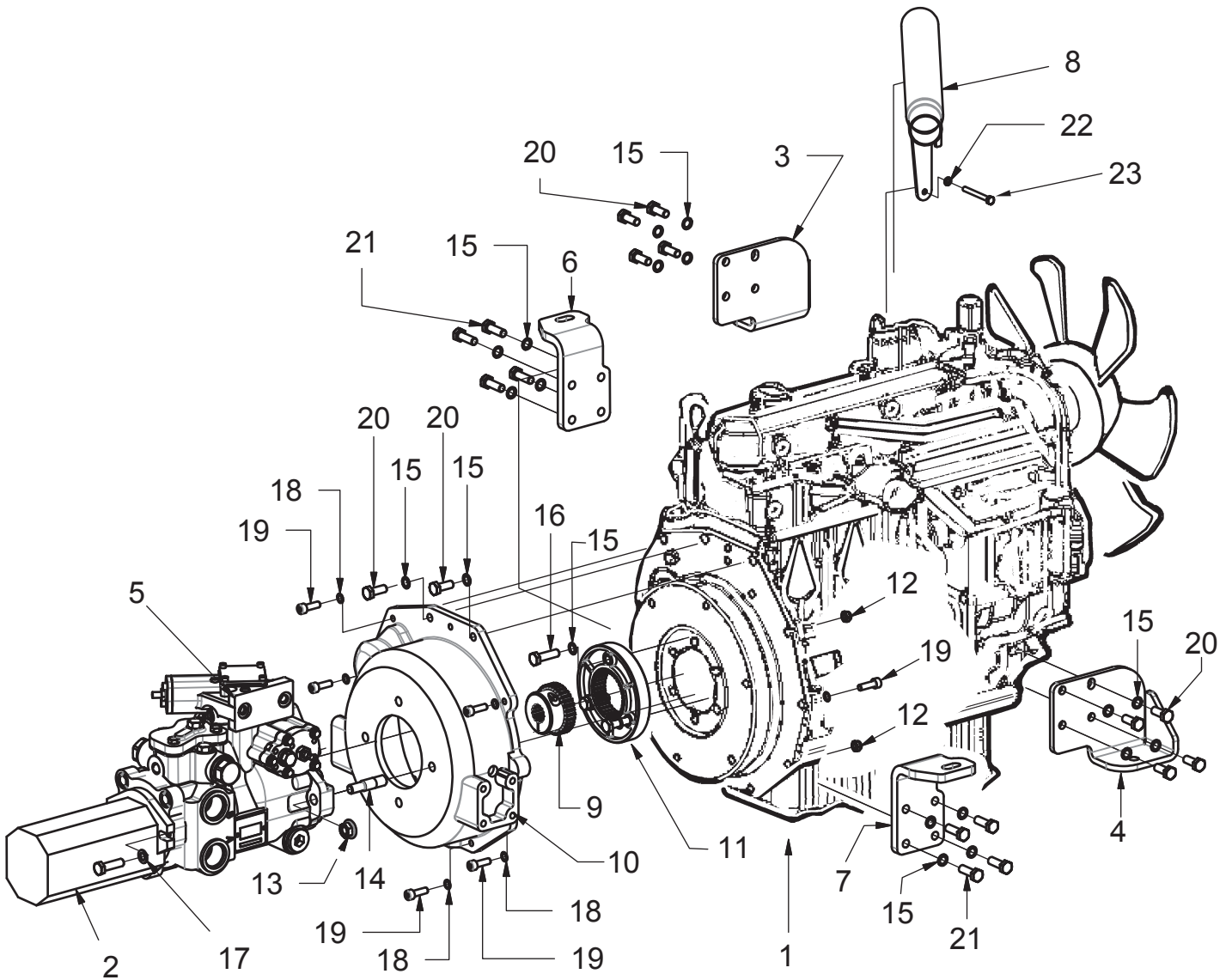

Ref.	Leg.	Code	Q.ty	Ref.	Leg.	Code	Q.ty
1	1505	00.54.01.0040	1	12		00.26.05.0060	2
1	1100	00.54.01.0030	1	13		00.26.09.0070	2
2		00.41.00.3540	1	14		01.40.20.0011	2
3		01.60.20.0099	1	15		00.68.12.0010	21
4		01.60.20.0082	1	16		00.92.06.3090	3
5		00.41.00.3550	1	17		00.68.01.0040	2
6		01.60.20.0177	1	18		00.68.12.0008	8
7		01.60.20.0180	1	19		00.90.06.0100	8
8		01.50.20.0095	1	20		00.92.06.3050	10
9		00.55.01.0843	1	21		00.92.06.3081	8
10		00.55.01.0851	1	22		00.68.01.0020	1
11		00.55.01.0852	1	23		00.92.03.1160	1

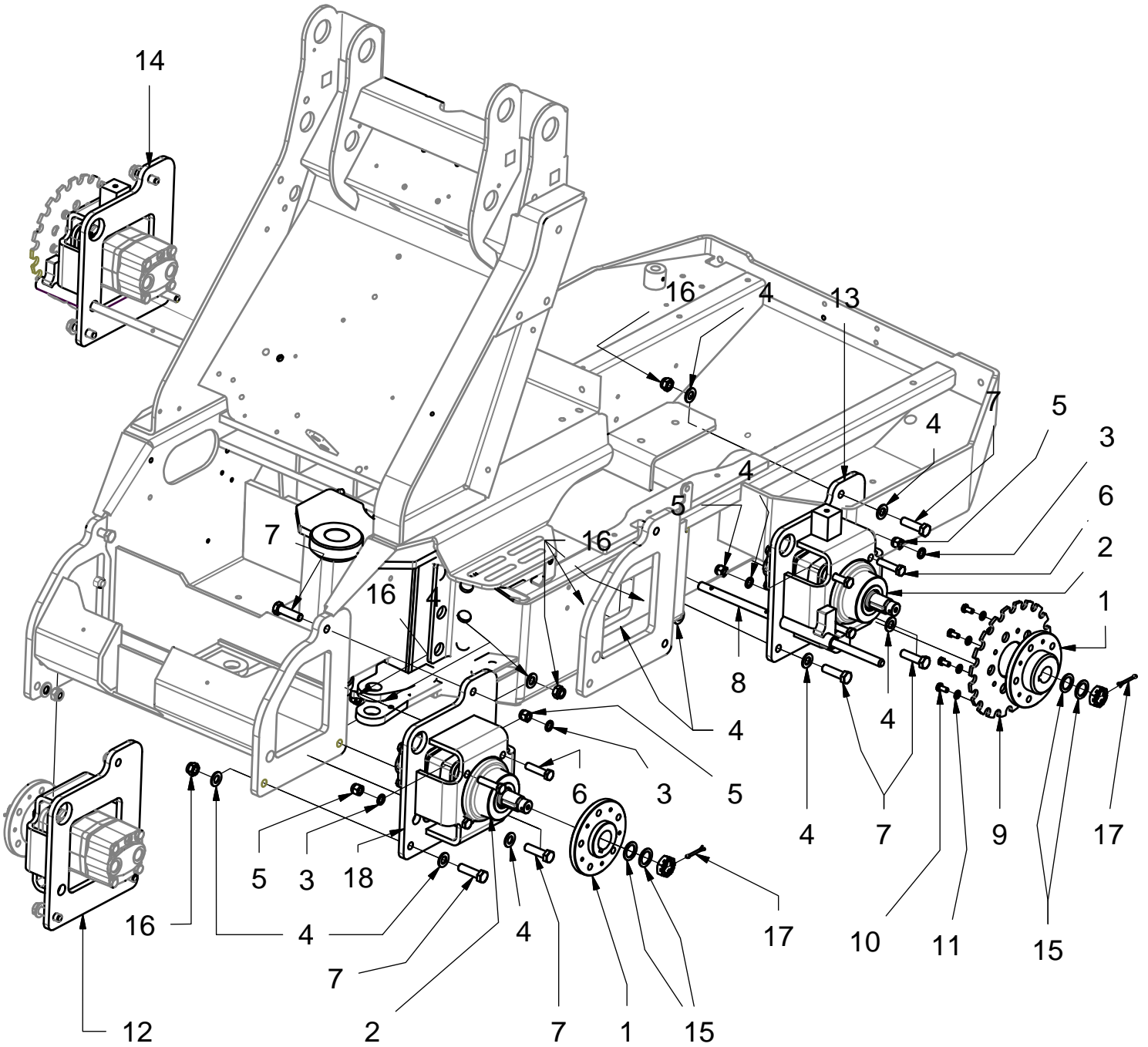

Ref.	Leg.	Code	Q.ty	Ref.	Leg.	Code	Q.ty
1		01.40.20.0010	4	10		00.92.05.1040	10
2		00.54.00.1160	4	11		00.68.01.0030	10
3		00.68.01.0050	16	12		01.50.20.0062	1
4		00.68.01.0060	22	13		01.50.20.0064	1
5		00.26.04.0080	16	14		01.50.20.0063	1
6		00.92.07.0110	16	15		00.68.08.0505	8
7		00.92.08.1100	12	16		00.26.05.0090	12
8		01.40.20.0041	2	17		00.18.04.0065	4
9		01.50.20.0011	2	18		01.50.20.0061	1

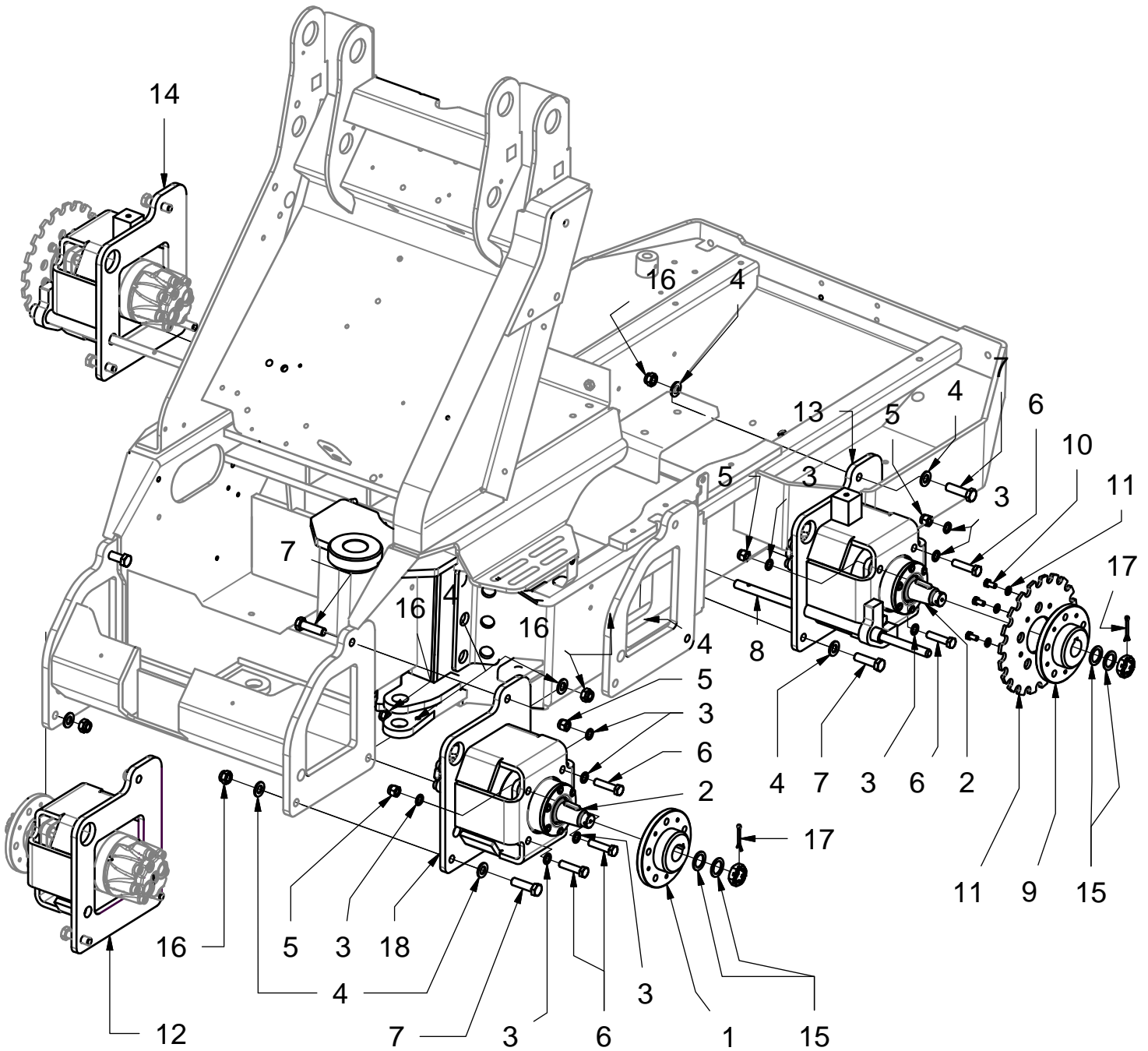

Ref.	Leg.	Code	Q.ty	Ref.	Leg.	Code	Q.ty
1		01.40.20.0010	4	10		00.92.05.1040	10
2		00.54.00.1170	4	11		00.68.01.0030	10
3		00.68.01.0050	16	12		01.50.20.0059	1
4		00.68.01.0060	22	13		01.50.20.0070	1
5		00.26.05.0090	16	14		01.50.20.0080	1
6		00.92.07.0110	16	15		00.68.08.0505	8
7		00.92.08.1100	12	16		00.26.05.0090	12
8		01.40.20.0041	2	17		00.18.04.0065	4
9		01.50.20.0011	2	18		01.50.20.0058	1



P R O F E S S I O N A L M O W E R S

GIANNI FERRARI s.r.l. • Via Vespucci, 53 (Zona Ind. Ranaro) • 42046 REGGIOLO (RE) Italy • Tel. 0522 / 973697 • Fax 0522 / 973707

www.gianniferrari.com [e-mail:info@gianniferrari.com](mailto:info@gianniferrari.com)